

Temperature Transmitter Data Sheet

SBWR/Z Serial Temperature Transmitter Din-Rail Mounting Type

Introduction

- SBWR serial thermocouple temperature transmitter and SBWZ serial RTD temperature transmitter is a spot mounted temperature transmission unit in DDZ-S serial instruments and meters .
- It adopts the two-wire transmission method (the power input and the signal output are two communal conductors).
- There is a linear 4~20mA current signal between the output and the measured temperatures.
- The transmitter may be installed inside the terminal box of the thermocouple and the thermal resistance to form an integral structure, and also independently mounted in the instrument panel as a change-over unit.
- Application: To be a new generation thermometric meter, it is widely applied in the industrial and scientific research fields such as petroleum, chemicals, textile, metallurgy, electro-machinery, electric force, aviation, food, processing, pharmaceutical engineering, etc for the purpose of automated temperature testing, transmitting and controlling.
- Working principle:
Thermal resistance or thermocouple temperature sensors convert the measured temperature into an electrical signal. Then the signal is sent to the transmitter conversion amplifier circuit (operation and compensation) with 4 ~ 20mA DC current output , which also can be converted by the A/D to display the site temperature on LED (LCD) meter at the same time.

Features:

- ◆ Owing to its epoxy resin sealing structure, it is aseismatic and temperature resistant, suitable for installation and use in bad environment.
- ◆ It can be directly installed in the terminal box of the thermal resistance and thermocouple, and directly output 4 ~ 20mA or 0 ~ 10mA signals, which not only saves the cost of the expensive compensation conductor, but also improves the anti-interference ability of the signal during long distance transmission.
- ◆ High precision, low power consumption, wide temperature range, stable and reliable performance.
- ◆ The range is adjustable and has a linearized correction function. The thermocouple temperature transmitter has the function of automatic compensation for cold end.
- ◆ It has a wide range of applications, which can not only form an integrated field installation structure with thermocouples and thermal resistors, but also can be installed into the testing equipment as a functional module.



CE RoHS

Technical Characteristics

Model	SBWR/Z Series
Input Signal	RTD: Pt100, Cu50, Cu100 (2-wire/3-wire/4-wire)
	Thermocouple: K, E, J, B, S, T, N (2-wire)

Temperature Transmitter Data Sheet

Output Signal	4 ~ 20mA DC
	4 ~ 20mA DC output signal can be linear with both the output resistance signal and input temperature signal of the resistance thermometer; It can also be linear with the output MV signal and input temperature signal of the thermocouple thermometer.
	For the intelligent transmitter, communication signals conforming to HART standard protocol can be superimposed at the same time of 4 ~ 20mA DC signal output.
Intrinsic Error	0.5%FS, 0.2%FS (Intelligent)
Mode of Connection	Two-wire/ Three-wire/ Four-wire system
Supply Voltage	<p style="text-align: center;">12~36V DC (Rated 24VDC)</p> <div style="text-align: center;"> <p>负载: (Ω)</p> <p>负载: Load</p> </div>
Load	Ultimate load resistance: $RL(\max) = 50 \times (V_{mm} - 12)$ That is, the load resistor can be selected in the range of 0~600Ω at 24V and the rated load is 250Ω .
	Remarks: For the range adjustable transmitter, zero and full scale need to be adjusted repeatedly to modify its range; The thermocouple transmitter must be preheated for 30 minutes before the debug.
Display Mode	Four LED/LCD shows any parameter of the site temperature or sensor value or current or percent range.
Influence of Ambient Temperature	$\leq 0.05\%1^{\circ}\text{C}$
Temperature Influence Coefficient	$\delta \leq 0.05\%/^{\circ}\text{C}$
Normal Working Environment	Temperature: -25~+80°C
	Relative Humidity: 5%~95%RH
Mechanical Vibration	$f \leq 55\text{Hz}$ Amplitude $< 0.15\text{mm}$
Case Material	ABS
Overall Dimension	104×45×26 mm
Installation	DN315mm Standard Rail

Temperature Transmitter Data Sheet

Naming Rules Part Number Coding

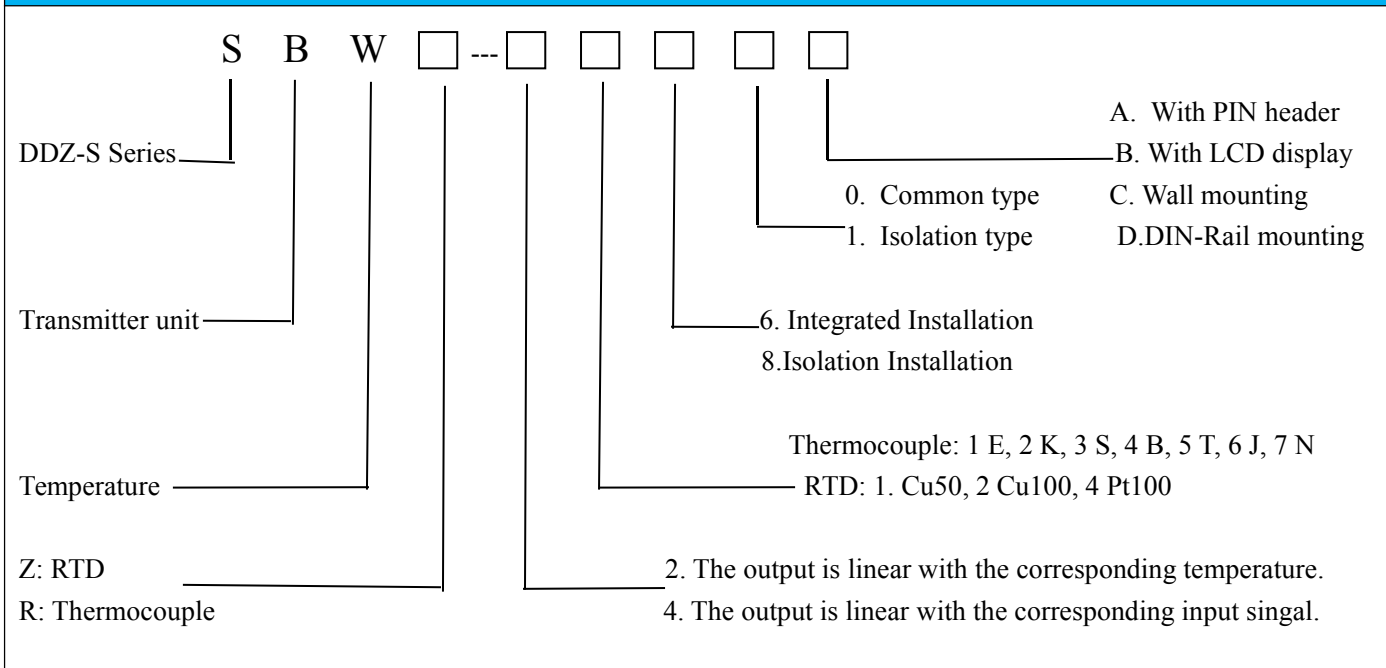

Connection Mode

Installation wiring diagram of thermoelectric resistance transmitter 3-wire type:

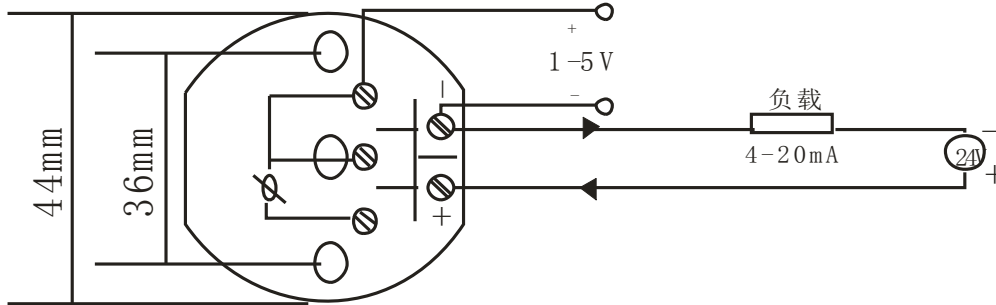

负载: Load

Installation wiring diagram of thermoelectric resistance transmitter 2-wire type:

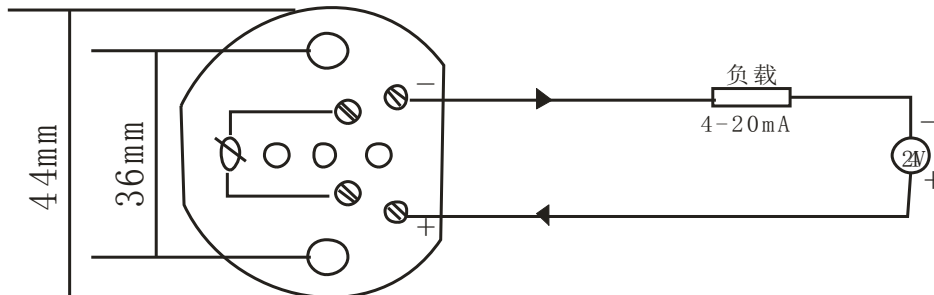

负载: Load

Temperature Transmitter Data Sheet

Installation wiring diagram of thermocouple transmitter:

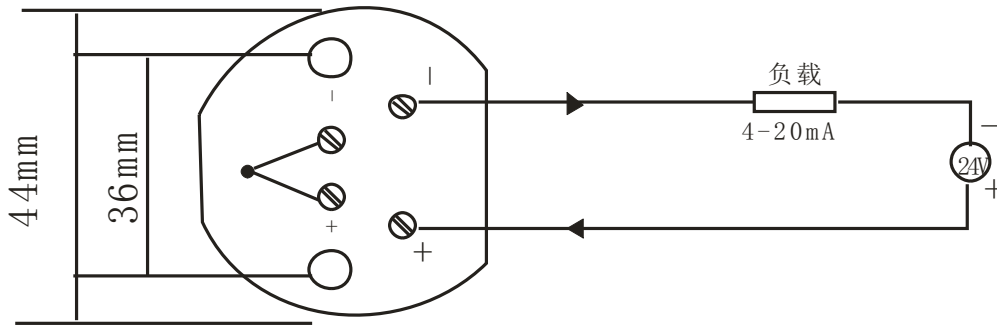

:负载: Load

Installation wiring diagram of DIN-Rail Mounting type transmitter:

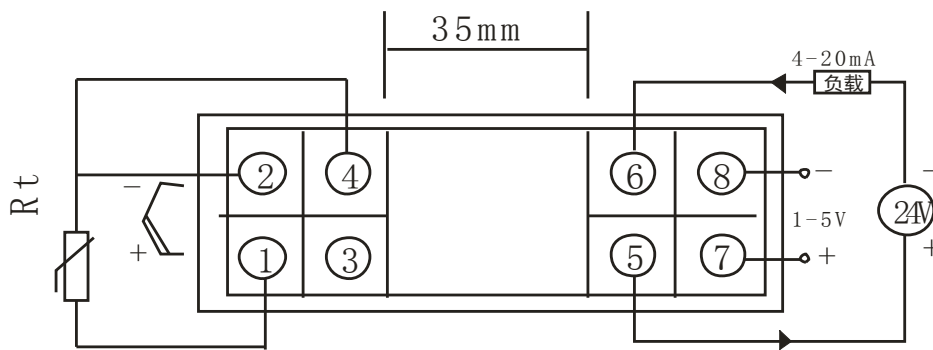

负载: Load

Installation wiring diagram of integrated LCD display transmitter:

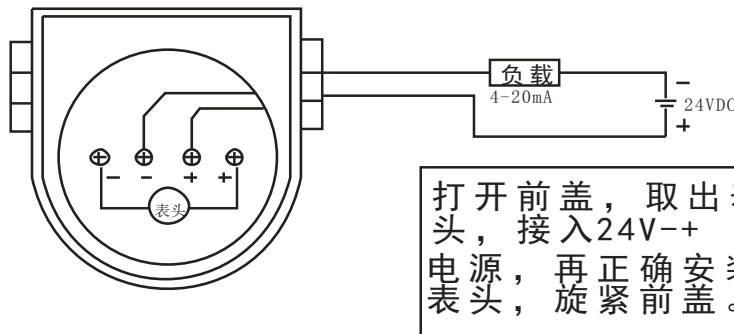

负载: Load

Open the front cover and take out the gauge outfit, connect to $\pm 24V$ power supply, then install the gauge correctly and finally tighten the front cover.

Checkout Steps of the Thermocouple Temperature Transmitter

1. When checking, the potentiometer is accessed at the input end, the output signal is EMF, and the 24VDC power supply is connected to the output terminal and the standard ammeter is connected in series.
2. Zero adjustment: Reverse connecting signal input line, so that the potentiometer output the on-site room temperature corresponding to electromotive force, adjust the potentiometer Z, so that the readout of the ammeter is 4mA.
3. Full adjustment: Connecting the signal input line, so that the potential difference meter output full range corresponding to the EMF, adjust the potentiometer S, so that the readout of the ammeter is 20mA. (The electromotive force is a full degree EMF minus the value of the EMF at room temperature)

Temperature Transmitter Data Sheet

Checkout Steps of the Thermal Resistance Temperature Transmitter

1. Connecting according to the above typical wiring diagram, access the standard resistance box at the input end (such as ZX-25a), connect the 24VDC voltage at the output terminal and connect the standard current meter in series.
2. Change the signal generator (resistance box), make it equal to the lower limit of the range, adjust the potentiometer Z, make the reading of the ammeter 4mA, change the signal source, make it equal to the upper limit of the range, adjust the potentiometer S, make the reading of the ammeter 20mA.

Installation & Use

1. The temperature transmitter module can be used normally after the correct connection.
2. When the integrated digital display transmitter is installed, open the front cover and take out the gauge outfit, connect to $\pm 24V$ power supply, then install the gauge correctly and finally tighten the front cover.
3. The instrument should be checked once a year. If it is used in the environment of strong vibration or corrosive gas, it should be checked once a half year. When the basic error is greater than the allowance, it can be adjusted by the professional personnel.
4. The environment shall be in accordance with the requirements of the technical requirements.
5. When ordering, please indicate the model, graduation number, measurement range and other additional functions on the contract.