



DATA SHEET

Hall Effect Current Sensor

PN: CHB500CAB12SCAN

I_{PN}=500A

Description

The CHB_CAB series current sensors are suitable for EV battery monitoring applications, providing high accuracy and extremely low zero error. When measuring, the primary side (high voltage) and secondary side fully insulated (12V system) .

Feature

- Temperature calibration closed-loop principle
- +12V battery voltage supply
- Configurable CAN speed
- Output signal high-speed CAN (500kpbs)
- Configurable CAN ID



Advantages

- Excellent accuracy
- Low temperature drift
- Wide working voltage range
- Strong anti-interference ability



Applications

- Electric vehicle battery pack
- Traditional lead-acid batteries
- Battery management applications for precise current measurement (SOC, SOH, SOF, etc.)



RoHS



Electrical data:

PARAMETERS	SYMBOL	UNIT	VALUE			CONDITIONS
			MIN.	TYP.	MAX.	
Over voltage	U _C	V		32		400 ms
Over voltage	U _C	V		24		10 minutes
Over voltage	U _C	V		20		Continuity
Reverse voltage	U _C	V		-50		10 minutes
Minimum power supply voltage	U _C	V		6		Continuity
Maximum power supply voltage	U _C	V		18		Continuity
Insulation resistance	RIS	MΩ		500		500 V - ISO 16750-2
Creepage distance	dCp	mm		7.5		
Electrical clearance	dCI	mm		7		



Cheemi Technology Co., Ltd

Insulation AC test voltage		KV		5		50Hz, 1min
Insulation DC test voltage		KV		5		1min

Working performance parameters:

Electrical data:

PARAMETERS	SYMBOL	UNIT	VALUE			CONDITIONS
			MIN.	TYP.	MAX.	
Measuring current range DC	I_{PN}	A	-500		50 0	
supply voltage	U_C	V	7	12	18	
Current consumption	I_C	mA	-	21	30	@ $I_P=0$
Current consumption	I_C	mA	-		25 0	@ $I_P=500A$
Working temperature	T_A	°C	-40		85	

Performance parameter:

Maximum voltage hysteresis	U_{UP}	V		18.1		When U_C rises
		V		17.7		When U_C drops
Minimum voltage hysteresis	U_{LOW}	V		7.1		When U_C rises
		V		6.8		When U_C drops
Total accuracy	XG	%	-0.3		0.3	
Linearity error	ϵ_L	%	-0.1		0.1	
Zero point error	I_{OS}	A	-0.1		0.1	$T=-40$ to $85^\circ C$; $\pm 3\sigma$
Gain temperature coefficient	TCG	ppm/°C		10		$T=-40$ to $85^\circ C$; $\pm 3\sigma$

Full temperature accuracy error@(-40°C~85°C) , $\pm 3\sigma$

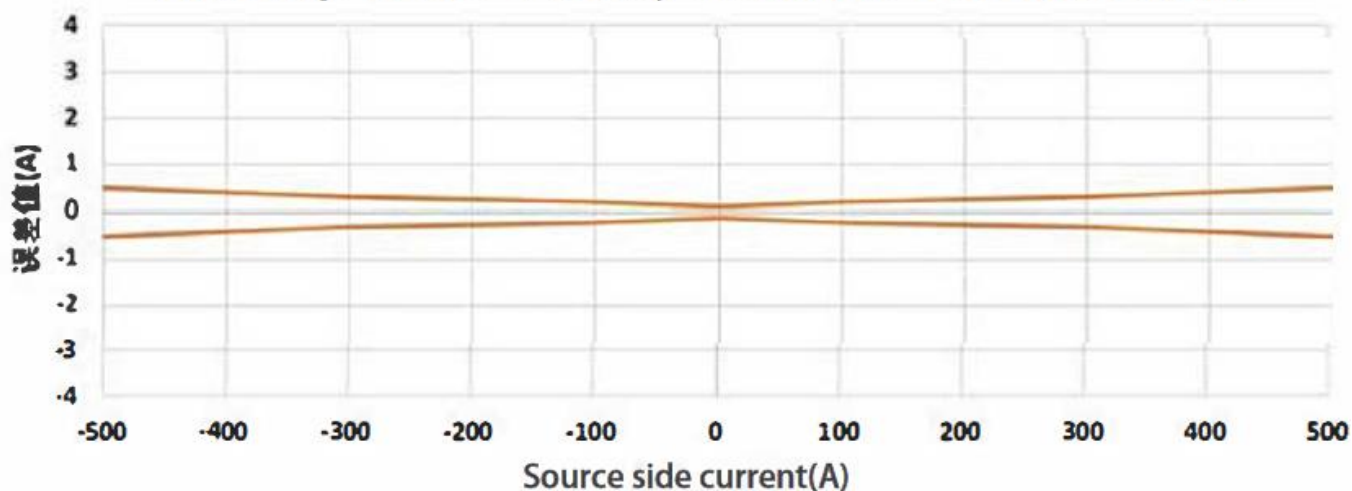

CAN bus electrical parameters

CAN bus baud rate: 500kbps

CAN bus protocol: 2.0A/B

CAN oscillation error: 0.3125%

Byte order: big endian (Motorola)



Cheemi Technology Co., Ltd

Tel: 025-85996365

E-mail: info@cheemi-tech.com

www.cheemi-tech.com

Add: N22, Xianlongwan, Xianyin South Road, Qixia District, Nanjing - China.

Message Description	CAN ID	Data length	Message Launch type	Signal description	Signal name	Start bit	Length
Return current IP (mA)	0x3C2	8 bytes	Cyclic transmitted message 10ms cycle	IP value: 80000000 h=0mA 7FFFFFFFh=-1mA 80000001h=1mA	IP_VALUE	24	32
				Error information	ERROR_INFORMATION	32	7
				Error indication(1bit) 0=normal, 1=failure	ERROR_INDICATION	39	1
				Fixture to 0	VACANT_DATA_2BYTES	48	16
				CRC-8 POLY:8+X2+X+1	CRC_8	56	8

Fault diagnosis code (fault information)

Failure mode	IP value	Error indication	Error information
Flash CRC error	FFFF FFFF h	1	0x48
AFE over range happens	FFFF FFFF h	1	0x49
AFE error happens	FFFF FFFF h	1	0x50
Internal LUT error	FFFF FFFF h	1	0x51
Power Minimum Limit	FFFF FFFF h	1	0x54
Power Maximum Limit	FFFF FFFF h	1	0x55

General data:

Parameter	Value
Operating temperature TA(°C)	-40 ~ +85
Storage temperature TS(°C)	-55~ +125
Mass M(g)	65
Plastic material	PA66+GF30
Standards	ISO16750
	GB/T28046
	IEC60068



Dimensions (Undeclared tolerance $\pm 0.5\text{mm}$):

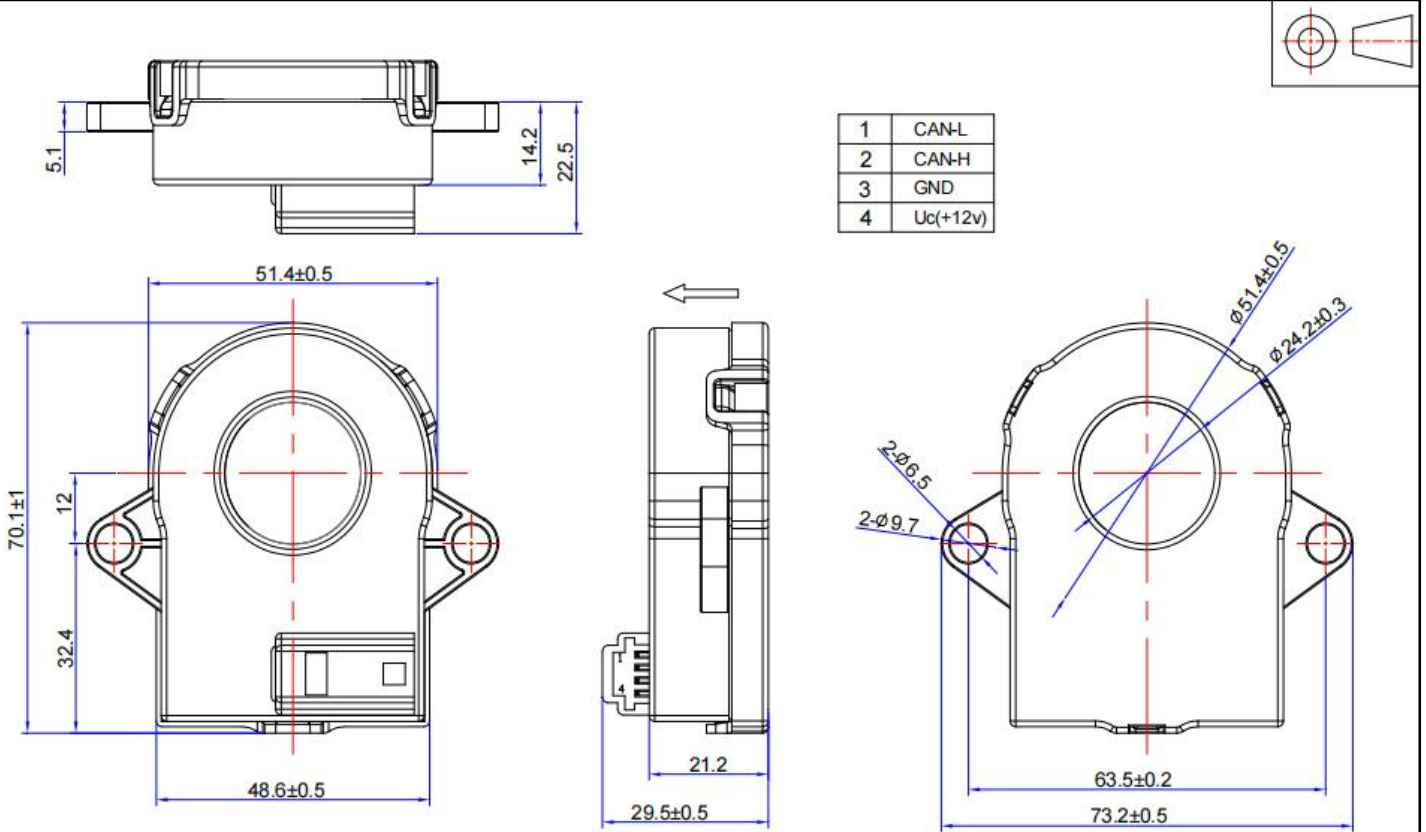

Connect

1	CAN-L
2	CAN-H
3	GND
4	Uc(+12v)

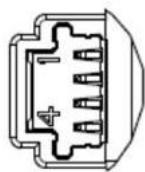

Bill of Materials

- Plastic shell: PA66+GF30
- Magnetic core: thin film alloy winding
- Connector terminal: Tinned brass
- Weighing: About 65g

Mounting recommendation

Connector model TYCO: 1473672-1
Recommended maximum torque M6=3Nm

Remarks:

- When the current goes through the primary pin of a sensor, the voltage will be measured at the output end.
- Custom design is available for the different rated input current and the output voltage.
- The dynamic performance is the best when the primary hole is fully filled with.
- The primary conductor should be $<100^{\circ}\text{C}$.

WARNING : Incorrect wiring may cause damage to the sensor.

